

US-2000 AD 360x260 60mm The modular built banding machine

A

Tech Specs

Weight net	90 kg ¹
Pallet size for shipment (Length x Width x Height)	120x80x155 cm (for 1-2 Machine)
Working height	860-1030 mm
Pneumatic connection	6 bar
Display languages	cs, da, de, en, es, fi, fr, it, nl, no, pl, pt, sv

Features

- ✓ Easy, efficient and compact machine
- ✓ High machine safety and easy access
- ✓ Height adjustable and powerful performance
- ✓ With Digital control unit DCP 2000

Basic package

Nr.	Mechanical build
	✓ Arch size 360x260 mm (628767)
	✓ Standard colour RAL 5012
	✓ Standard 3-way dispenser
6E	✓ Control unit on arch
29E	✓ Square housing with side door (260-360 mm)
50E	<input type="checkbox"/> Sonotrode 41 mm with ATS logo
55E	✓ Air supported arch

Nr.	Electrical build
	<input type="checkbox"/> Connection 200-240 V ~ 50-60 Hz
	<input type="checkbox"/> Connection 100-120 V ~ 50-60 Hz

Max. cycle time / min³

Arch	Min. Product ⁴	Max. Product ⁵
360x260	23	28

Options

Nr.	Mechanical options
19E	<input type="checkbox"/> Print mark reader front + center
19E1	<input type="checkbox"/> Print mark reader in the front, center and rear ²
25E	<input type="checkbox"/> Support finger, adjustable, 2 pieces
38E	<input type="checkbox"/> Band centering, height adjustable
50E1	<input type="checkbox"/> Sonotrode 41 mm neutral
53E	<input type="checkbox"/> Foot pedal bracket

Nr.	Electrical options
1E	<input type="checkbox"/> Exchange signals
15E	<input type="checkbox"/> Band end predetection (without lamp)
27E	<input type="checkbox"/> High performance encoder + sensors
39E	<input type="checkbox"/> Product presence photocell from above
58E	<input type="checkbox"/> Product memory for up to 8 products
58E2	<input type="checkbox"/> Product selection via external signals

Additional equipment

Nr.	Equipment
	✓ Foot pedal

¹ Weight of the base package (without additional options)

² Depending on layout of the pre-printed band

³ With ideal infeed and machine settings

⁴ Dimension minimum product circumference = 100 mm

⁵ Dimension maximum product circumference generally 20 mm distance from arch

Layout example US-2000 AD 360x260/60

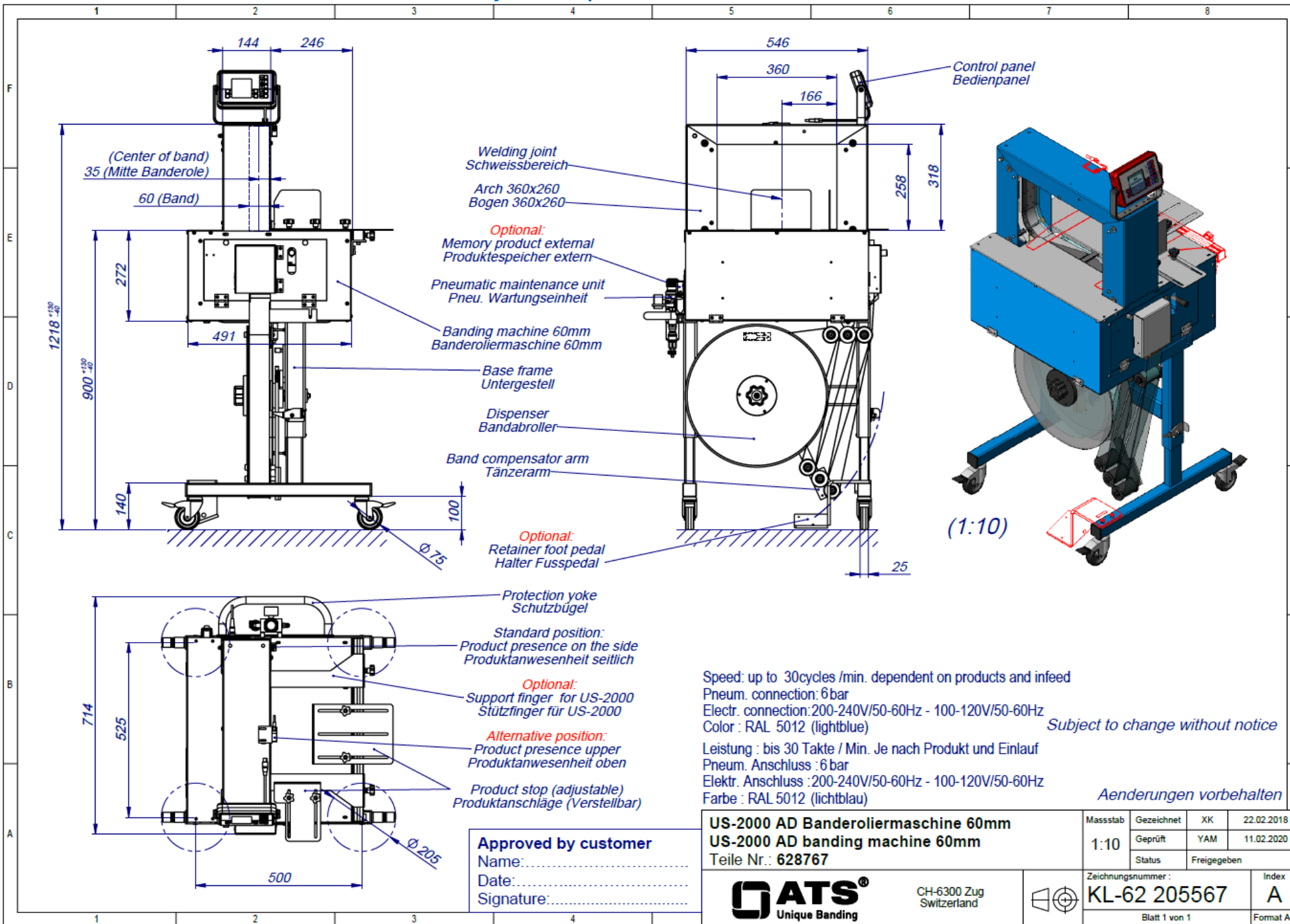

Approved by customer
 Name:.....
 Date:.....
 Signature:.....

US-2000 AD Banderoliermaschine 60mm
US-2000 AD banding machine 60mm
 Teile Nr.: 628767



Masstab	Gezeichnet	XK	22.02.2018
1:10	Geprüft	YAM	11.02.2020
Status	Freigegeben		
Zeichnungsnummer:		Index	
KL-62 205567		A	
Blatt 1 von 1			Format A3

History

Version	Date	Author	Reason for change / Remarks
00	17.02.2020	MSC	First edition
01	02.03.2020	MSC	Classification added
02	21.04.2020	MSC	Option 27E + foot pedal added
03	28.07.2020	AMA	Options changed to new E-Numbers
04	27.07.2023	TOB	Pallet size adjusted
05	12.02.2024	TOB	Electrical options adjusted